

# ALAMO 5831

METRO COLLECTION

# H | S

## SIZE

- 58.31.21

## WATER CAPACITY

- 65 Gallons

## WEIGHT

- 260 Pounds

## BACK SLOPE

- 28°

## MATERIAL

- Hydroluxe SS™

## STANDARD COLORS

- White, Almond, Biscuit

## PREMIUM COLORS

- Black, Carmine Red, Concrete Grey, Distant Blue, Grey Beige, Moss Green, Orange Brown, Pastel Violet, Purple Violet, Red Orange, Sapphire Blue, Signal Orange, Tarpaulin Grey, Terra Brown

## FINISH

- Matte, Polished, Two-Tone

## WARRANTY

- 10 years



## OPTIONS (more information available on our website)

- Air System
  - Blower and Control Panel Must be Remotely Located
  - Electrical Requirements (1) 15 AMP dedicated GF - 115 Volts
- Cold Plunge
- Hydro Coat
- Hydro Fusion
- Hydro Indulge
- Island Tub Drain
- Tower



## INSTALLATION VIDEOS AVAILABLE ON WEBSITE

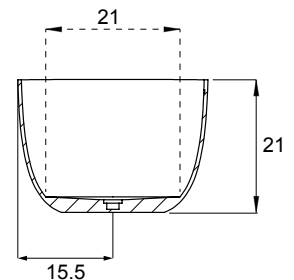
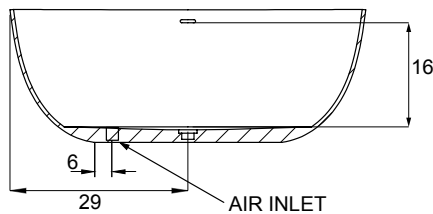
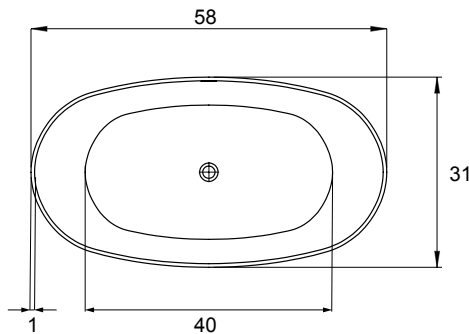

## CODES AND COMPLIANCES

Massachusetts code File no: P1-0614-491



**HYDRO SYSTEMS**  
Family Owned And Operated Since 1978

29132 Avenue Paine, Valencia, CA, 91355  
661.775.0686 | hydrosystem.com



MADE IN AMERICA

All specifications and options subject to change without notice please contact a hydro systems representative for more information.