

Cold Plunge Chiller

— INSTALLATION GUIDE —

Table of Contents

Items Included with Cold Plunge System	2
Installing the Chiller	3
Control Box Wiring	5
Chiller Display Panel	6
Warnings	7
Operating the Chiller	7
Setting the Temperature	8
Calibrating the Temperature	8
Programming a Temperature Deadband	9
Compressor Protection Mode	9
Two-Button Keypad Instructions	9
Cleaning and Maintenance	11
Error Codes and Solutions	12
Cold Plunge Chiller & Pump 1-Year Limited Warranty	13

Items Included with Cold Plunge System

1. Chiller Unit with connectors from pump to chiller to UV Ozone
2. Recirculating Pump
3. UV Ozone with Flex PVC pipe
4. 901 Control Box
5. Two-button Keypad (pre-installed in tub)
6. Low water protection wires
7. Temperature probe
8. 3 feet of PVC pipes color coded for connection

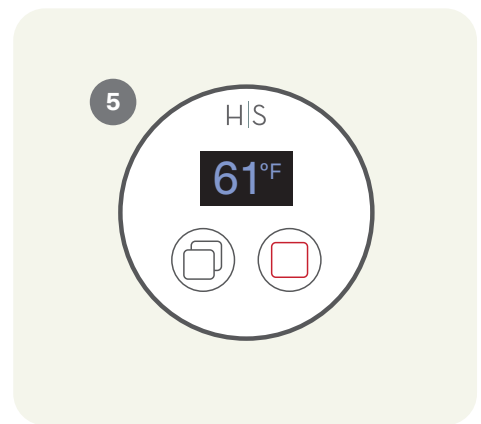
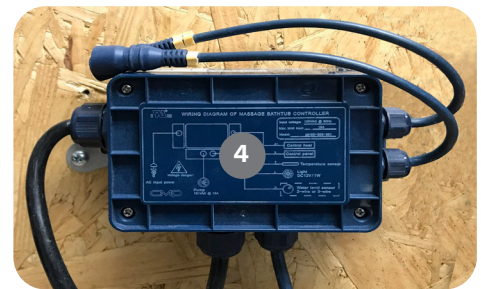

Installing the Chiller

1. Your bathtub comes pre-plumbed and ready for easy connection to the pump, chiller, and HydrOzone UV system.
2. Due to ventilation requirements and heat produced, we recommend installing the chiller outside. When installing outside, you must place the chiller inside a suitable structure that will protect it from direct sunlight and precipitation, while still allowing for proper ventilation. For reference, in our example picture (page 4) the structure built to house all equipment is 30"(l) x 28"(w) x 33"(h). Your structure can be smaller, but always leave room for proper ventilation. There should be at least 6" of space at the back of the chiller, where most of the heat is generated. We recommend 12" for optimal performance.
3. If you decide to install the system inside, please be aware that the chiller produces a good amount of heat, so take this into consideration when deciding where to place the chiller. If the rear of the chiller is placed against a wall, it should be at least 6" away from the wall to allow for proper ventilation. We recommend 12" for optimal performance.
4. The chiller itself must be installed on a flat surface, at approximately the same height as the bathtub. For optimal performance we recommend placing the chiller no further than 3 feet from the bathtub. The chiller can be installed up to 8 feet from the bathtub, but the further from the tub, the less efficient the chiller will be and the longer it will take to cool the water in the tub.

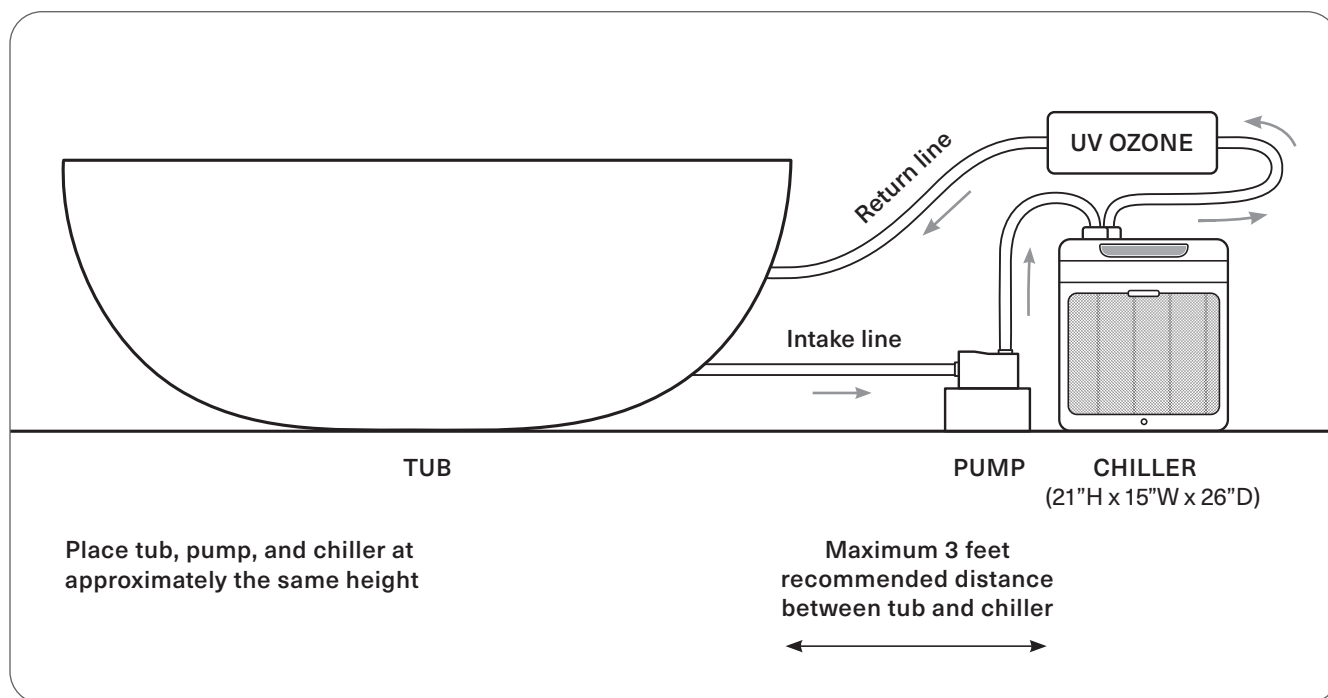

SETUP AND PLUMBING

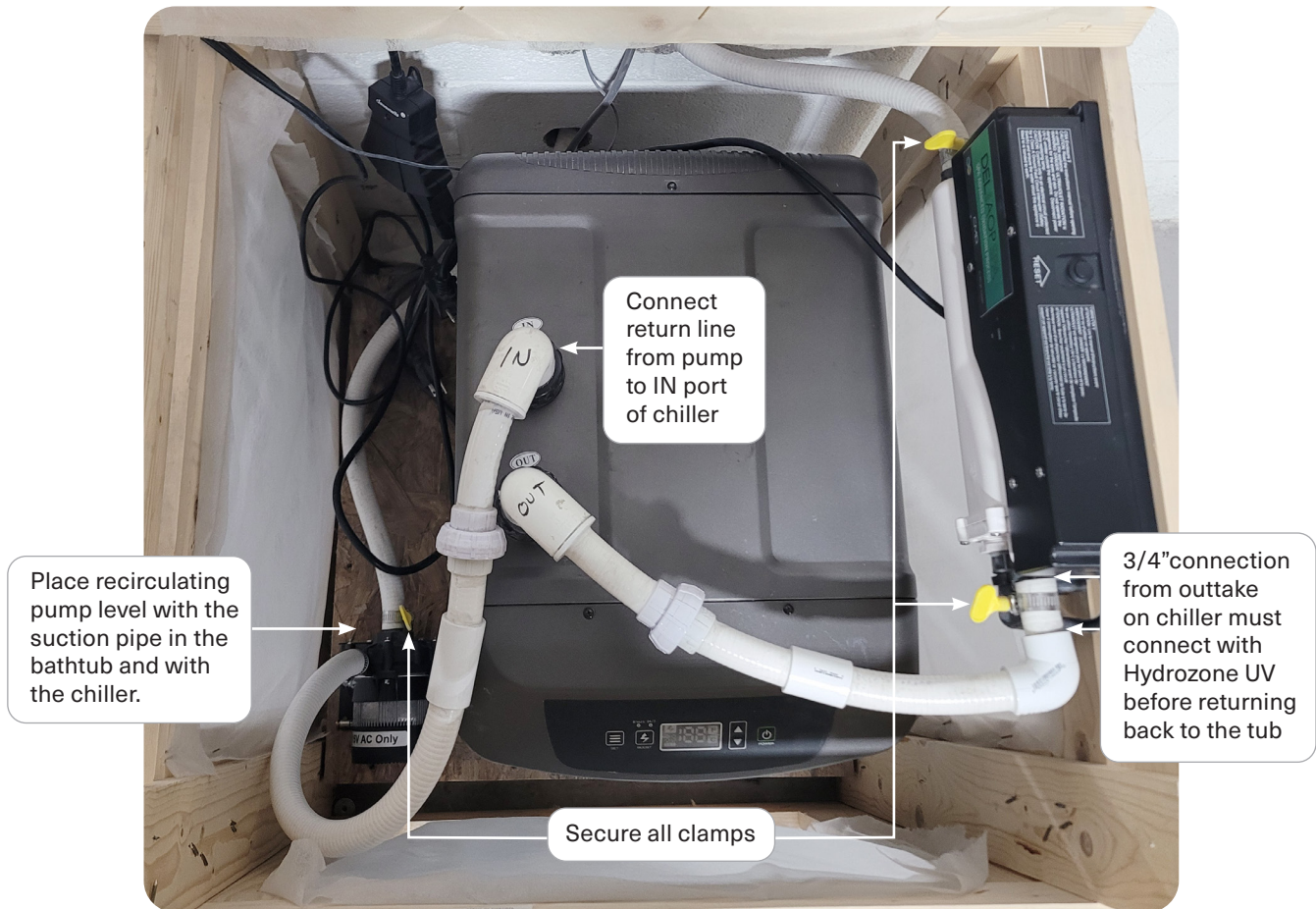

5. For ease of access, in case any future service is needed, we recommend that the pump, chiller, and HydrOzone UV all be remotely located together. We have included a model picture for how you should setup and plumb this system on this page. The recirculating pump must be located at approximately the same height as the suction pipe in the bathtub, and the chiller. The plumbing line coming from the suction in the bathtub should first go through the recirculating pump, then go into the chiller, and then finally through the HydrOzone UV before returning to the tub. Connect the plumbing from the bathtub to the pump, chiller, and HydrOzone UV, securing the hoses to the barb fittings with clamps provided. IN=Suction. OUT=Return.
6. The chiller must be installed with a dedicated 110-volt 20-amp GFCI receptacle.
7. Once all the connections are made and the bathtub is filled with water, please use the Display Panel on the chiller to set the unit to your desired temperature (see pages 6 to 8 for detailed instructions).

Control Box Wiring

The diagram below shows how to connect the control box to the chiller, recirculating pump, and UV ozone system.

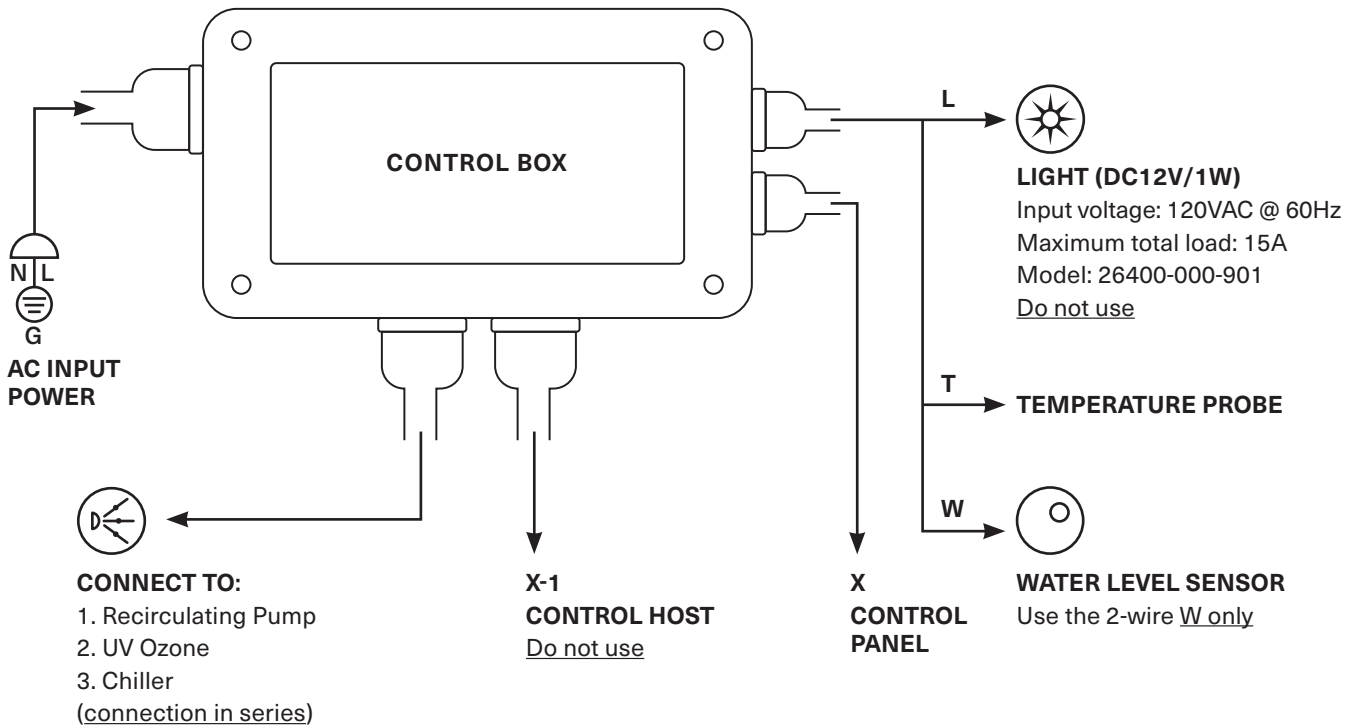

Chiller Display Panel

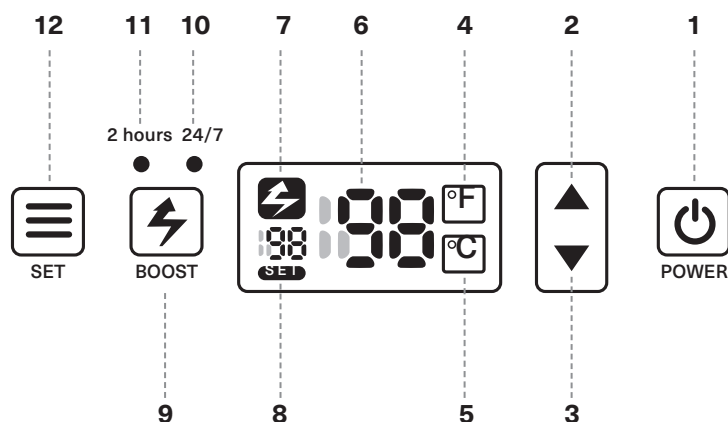

- 1 Power Switch**
Turns the chiller on and off.
- 2 Increase Temperature**
Increases temperature in one-degree increments. Select Fahrenheit as unit of measurement.
- 3 Decrease Temperature**
Decreases temperature in one-degree increments. Select Celsius as unit of measurement.
- 4 Degrees Fahrenheit**
Indicates that the current temperature is displayed in degrees Fahrenheit.
- 5 Degrees Celsius**
Indicates that the current temperature is displayed in degrees Celsius.
- 6 Water Temperature**
Displays the current water temperature.
- 7 Boost Indicator**
Lights up when the Boost function is active.
- 8 Set Temperature**
Indicates the user's setting of water temperature.
- 9 Boost**
Press to turn on Boost function (accelerates chilling).
- 10 Continuous Boost Indicator**
When lit, indicates that the 24/7 Boost function is active.
- 11 2-hour Boost Indicator**
When lit, indicates that the 2-hour Boost function is active.
- 12 Setting Mode**
Press to enter setting mode. Press again to confirm settings and exit setting mode.

Warnings

- Do NOT cover the chiller unit with anything that can restrict proper air circulation during operation.
- Place the chiller in the upright position ONLY for operation and storage purposes.
- Avoid direct contact with liquids to the external body of the chiller unit. Failure to do so may result in damage to the unit or electric shock.
- Keep power cord free of obstructions, such as heavy or sharp objects sitting directly on it.
- Keep the unit away from flammable vapors, direct sunlight, high temperature exposure, and high humidity.
- Do NOT submerge the chiller. Doing so will damage the unit and may inflict electric shock.
- When using the cold plunge it's best to keep sessions to times of **no longer than 10 minutes**. The most important thing is to listen to your body—this means getting out as soon as or shortly after you start shivering.
- Condensation can occur on the shell of bathtub and plumbing in more hot and humid environments, please plan your install accordingly.
- If installing chiller in un-insulated rooms in freezing environments, please make sure to use proper insulation on plumbing to prevent pipes from freezing.

Operating the Chiller

1. Before powering on the chiller unit, make sure your bathtub is filled with water.
2. Click the switch to ON position. The chiller will start to operate. The display panel will display the current water temperature and default desired water temperature immediately. However, the fan and compressor will be in protection mode for about 60 seconds before they turn on.
3. For the initial usage, turn on the unit by using the power button on the chiller display panel. Press the power button on the control panel again to resume operation.
4. The default desired water temperature is set at 75 degrees (Fahrenheit). The default unit of measure of temperature is Fahrenheit.
5. All Hydro Systems Cold Plunge systems come equipped with controls in the bathtub that will allow you to turn your system ON/OFF. For initial setup you must use controls on the chiller, but once properly programmed and calibrated, the control panel in the bathtub is all you will need to operate your Cold Plunge system.
6. Chiller will cool your bath water at an average of 4-8 degrees per hour. Exact rate will depend on ambient temperature and distance chiller is installed from bathtub.
7. While all Cold Plunge systems come equipped with HydrOzone UV to disinfect your water with ultraviolet light and destroy 99.99% of harmful microorganisms without adding chemicals, we still **recommend changing out your bath water at least every 3 days**.

Setting the Temperature

1. In Display mode, press either the \wedge or the \vee button for 5 seconds to select between Fahrenheit and Celsius as the unit of measure of temperature.
2. Press the SET button to enter the water temperature setting mode. The previous water temperature setting will display and blink after the setting mode is activated.
3. Use the \wedge or \vee button on the control panel to increase or decrease the water temperature. Press the SET button or wait for approximately 8 seconds to confirm the user-set temperature and exit from the setting mode to the display mode. The display will turn from blinking to solid.
4. The available range for user-set temperature is 39°F to 90°F (3°C to 32°C).

Calibrating the Temperature

1. Set the desired temperature above the current temperature so that the compressor will not operate during calibration.
2. In Display mode, press the \wedge or \vee button for 5 seconds to select between Fahrenheit and Celsius as the unit of measure of temperature.
3. Press and hold the \wedge and \vee buttons at the same time for 5 seconds to enter into the Calibration mode. The Current Temperature display will show zero and blink after the Calibration mode is activated.
4. If Fahrenheit is selected, each time you press either the \wedge or \vee button, the display will increase or decrease one unit, which represents 0.1 degree Fahrenheit. For example, to calibrate the temperature up 1 degree Fahrenheit, press the \wedge button 10 times and the display changes from zero to 10. To calibrate the temperature down 0.5 degree Fahrenheit, press the \vee button 5 times and the display changes from zero to -5.
5. If Celsius is selected, each time you press either the \wedge or \vee button, the display will increase or decrease one unit, which represents 0.1 degree Celsius. For example, to calibrate the temperature up 1 degree Celsius, press the \wedge button 10 times and the display changes from zero to 10. To calibrate the temperature down 0.5 degree Celsius, press the \vee button 5 times and the display changes from zero to -5.
6. Press and hold the SET button again for 5 seconds (or wait for approximately 8 seconds) to confirm the calibrated temperature and exit from the Calibration mode to the display mode. The display will turn from blinking to solid.
7. The temperature calibration range is +/- 5 degrees Fahrenheit or +/- 1.5 degrees Celsius.

Programming a Temperature Deadband

1. To protect the compressor from the stress of frequently turning on and off, a temperature deadband should be programmed. A temperature deadband is a temperature range above the set desired temperature in which the unit will not operate until the water temperature reaches the deadband upper limit. For example, if the desired temperature is set to 40 degrees Fahrenheit and the deadband is 2 degrees Fahrenheit, the chiller will chill the water to 40 degrees and then stop working and enter standby mode. The chiller remains in the standby mode until the water temperature rises and reaches 42 degrees. The chiller then resumes operation to chill the water down to 40 degrees and then again stop working and enter the standby mode.
2. The default deadband is 2 degrees in Fahrenheit or 1 degree in Celsius. If you would like to adjust the deadband range, please follow the following steps.
3. In Display mode, press the \wedge or \vee button for 5 seconds to select between Fahrenheit and Celsius as the unit of measure of temperature.
4. Press and hold the SET button for 5 seconds to enter into the deadband adjustment mode. The Current Temperature display will show the default deadband setting and will blink after the deadband adjustment mode is activated.
5. Use the \wedge or \vee button on the control panel to increase or decrease this setting to the desired deadband width. Press and hold the SET button again for 5 seconds (or wait for approximately 8 seconds) to confirm the desired temperature and exit from the setting mode to the display mode. The display will turn from blinking to solid.
6. The deadband setting range is 1-4 degrees Fahrenheit or 1-2 degrees Celsius.

Compressor Protection Mode

The refrigeration compressor will automatically turn off when the water reaches, or is below, the set temperature. After the compressor turns off, it will stay off for approximately 3 minutes.



Two-Button Keypad Instructions

The 2-button keypad, which comes pre-installed in your bathtub, controls the chiller, the recirculating pump, and the UV system.

Once the chiller has been installed and set up, you can use the 2-button keypad to turn the pump on or off. If you need to adjust the temperature, you can do so on the chiller display, as explained on page 8.

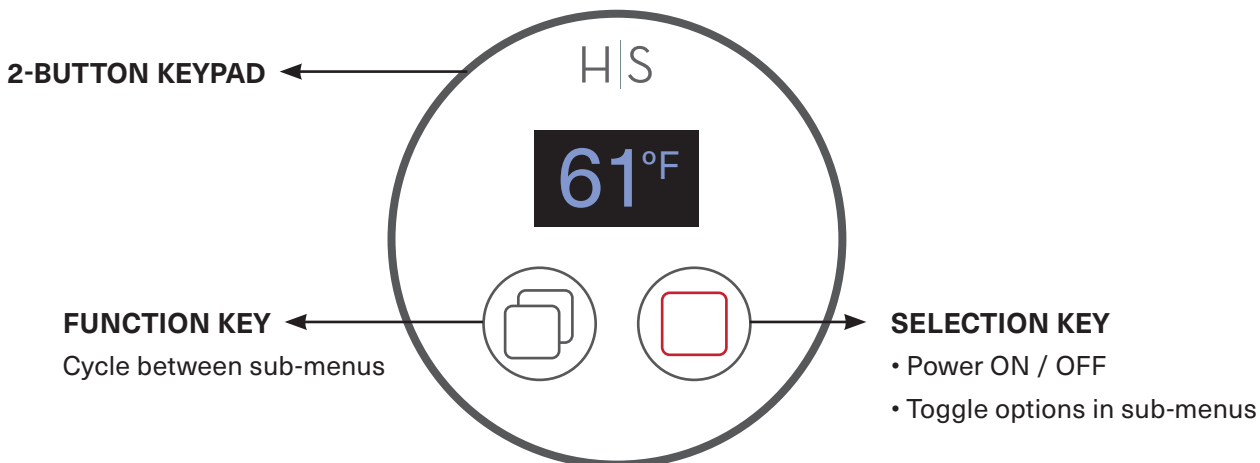
Please familiarize yourself with the features and operating instructions below in order to maximize the enjoyment you receive from your bath. These operating instructions should be used in conjunction with the other instructions and warnings provided with your whirlpool bathtub in order to fully understand and safely utilize the bathtub.

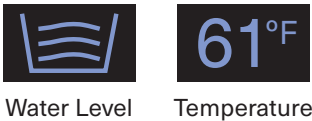
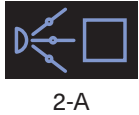

FUNCTION	LCD DISPLAY
<p>1. POWER ON (Activate System)</p> <p>a) Press and hold Selection Key to power up controller and activate the system. Display will cycle through water level and temperature at startup.</p> <p><i>NOTE: If water level is too low, system will not activate and display will show "low water level" icon.</i></p> <p>b) Press and hold Selection Key once to power OFF.</p>	 <p>Water Level Temperature</p>
<p>2. PUMP FUNCTIONS</p> <p>a) Press the Function Key to cycle to Pump menu.</p> <p>b) Press the Selection Key to toggle Pump ON/OFF.</p>	 <p>2-A</p>
<p>3. TEMPERATURE SETTINGS</p> <p>To change temp from °C to °F, press and hold the Function Key.</p>	 <p>4-A 4-A</p>

TROUBLESHOOTING	SOLUTION
<p>Low water level / no water. If the water level is too low, the system will not activate and the display will show the "low water level" icon.</p>	<p>Increase water level.</p>
<p>Pump does not turn on.</p>	<p>Check water level. Pump will not engage without a sufficient water level.</p>

Cleaning and Maintenance

We recommend that you clean the chiller housing for optimal performance and longevity every 6 months, depending on conditions and amount of dust or debris it collects.

Note: Do NOT use soap or detergents for cleaning the internal components of the chiller system. Do not spray or soak the unit with water to clean it.

1. Disconnect (unplug) the chiller from the power supply. Clean the chiller housing by using moisture towels.
2. Reconnect the pump to the chiller inflow tubing and place it in a clean reservoir.
3. Regular cleaning of the chiller's front and side air filter panels will help maintain and maximize the chiller's efficiency. Follow the steps below to remove and clean the air filters.

Cleaning the front air filter:

- Loosen the screw on the front panel and gently remove the panel
- Push the filter upward to unlock it from the unit, and remove it from the panel
- Use water and gentle brushing to wash the filter

Cleaning the side air filter:

- Lift and remove the side panel
- Loosen the screen on the side panel, and remove the filter
- Use water and gentle brushing to wash the filter

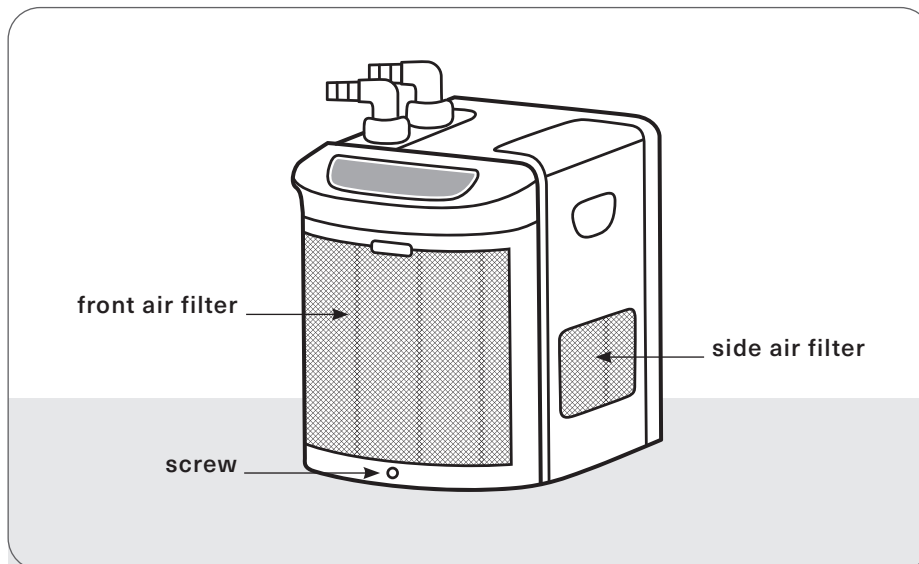

Error Codes and Solutions

ERROR CODE OR SYMPTOM	POSSIBLE CAUSE	SOLUTION
P1	Water temperature in reservoir or tank is at or below 32°F or 0°C degrees Celsius	Ensure that the pump is operating correctly for correct water circulation
P2	Water temperature in reservoir or tank is above 140 °F or 60 °C	Use other methods to reduce the water temperature down, or allow the water to cool by itself until the temperature falls below 140°F/60°C. Unit will resume operation automatically
E1	Temperature Probe malfunction	Temperature probe is loose or has become damaged. Contact your retailer for assistance
The unit does not run and the Control Panel has no power	Power is not turned on.	Turn on the power and be sure the power cord is fully plugged in
	Power supply being used is of incorrect voltage	Replace the fuse if it has been blown and plug the unit in to a power supply of the correct voltage. If the internal circuit board has been burned, contact your retailer for assistance. Please note that the warranty will be void if the incorrect power voltage is applied
The Control Panel is normal, but the fan and compressor do not turn on	Chiller is in compressor protection mode	If the fan and the chiller dissipate heat normally, wait for 3 minutes and the unit will automatically turn on again
	The set desired temperature is higher than the current water temperature	Reset the set (desired) temperature to a lower temperature than the current water temperature
The unit turns on and off more frequently than before	Fan is not working	Contact your retailer for assistance
	The air inlet or outlet are clogged	Clean the air inlet/outlet with a brush or a vacuum cleaner
The Control Panel is normal, but unit is not cooling	No refrigerant	Contact your retailer for assistance
Loud operation	Not installed on a flat surface	Relocate chiller to a location with a flat surface

Cold Plunge Chiller and Pump 1-Year Limited Warranty

This limited warranty on the cold plunger chiller and pump is extended to the first user or the original retail purchaser for a period of twelve (12) months from purchase. This limited warranty is not enforceable by any other party.

HYDRO SYSTEMS, INC. warrants that the system is free from defects in the workmanship and/or materials. This limited warranty does not include any other items not manufactured by HYDRO SYSTEMS.

No dealer or other person has any authority to make any warranties or representations concerning HYDRO SYSTEMS, INC. or its products. Accordingly, HYDRO SYSTEMS, INC. is not responsible for any such warranties or representations.